



**bellaform**  
the better solution

MACHINES AND EQUIPMENT  
FOR PLASTIC PROCESSING



## A 600 Takeoff

### Constant takeoff speeds for every extrusion line

Bellaform takeoffs offer accurate speed control and thanks to a servo drive always run at a constant takeoff speed – even when your plant is running at full capacity

**NOW  
IN A NEW DESIGN**  
Direct drive  
without toothed belt!

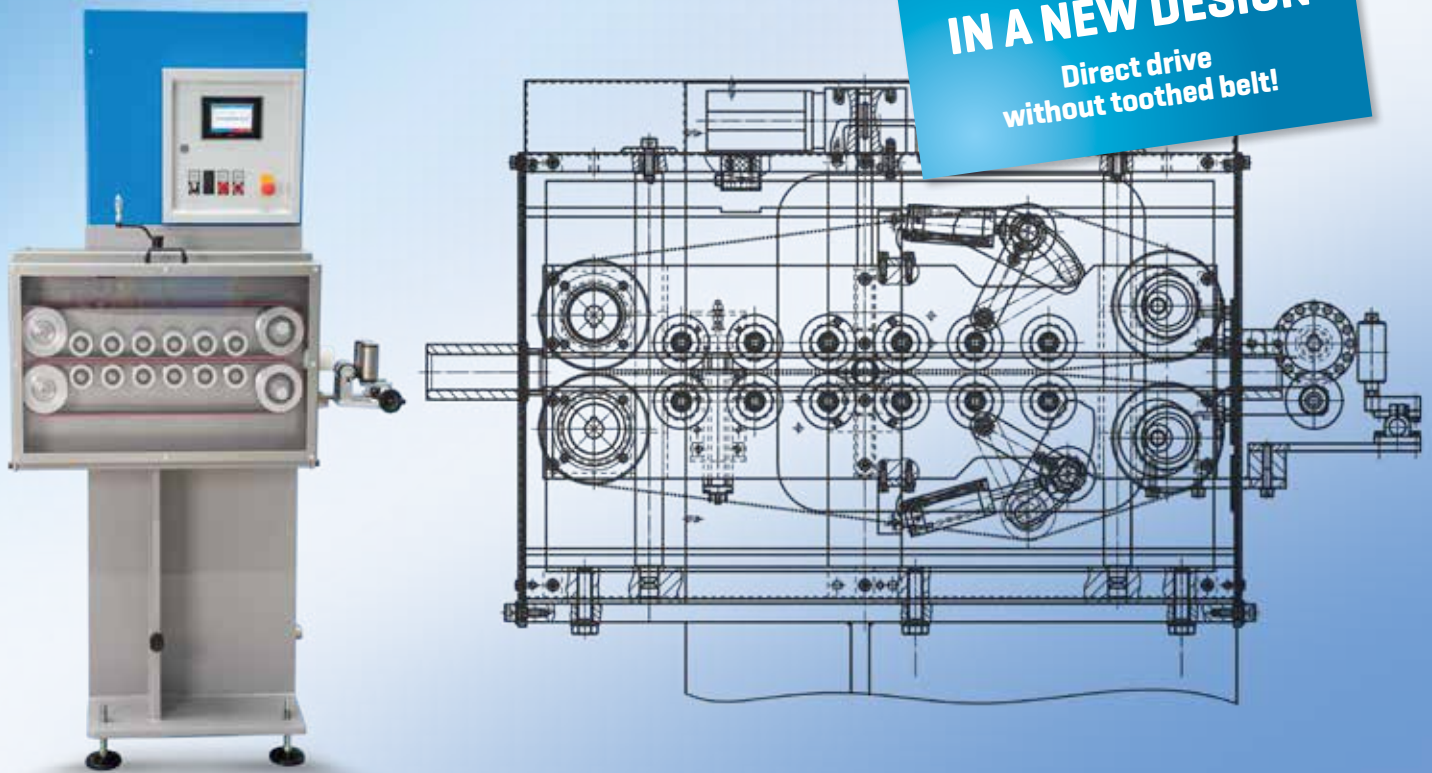

### Standard configuration:

- **Synchronous gap adjustments**  
(for constant product centring)
- **Movable upper and lower carriage**  
to protect the belts
- **Takeoff belts in the familiar  
Bellaform configuration**
- **The products are guided  
by side rollers**  
The roller spacing can be adjusted  
via a hand wheel on the roller guide
- **Mechanical height adjustments**  
(spindle/crank)
- **Individually driven belts**  
via 2 directly installed servo motors
- **Direct drive without toothed belt**
- **Internal protective housing**  
optical (and mechanical) division  
of the belt area

## Takeoff options:

- Electromechanical belt gap adjustments with measurement and display of the gap
- Product throughput monitoring via a counter wheel
- Quick opening – in the event of a malfunction, the lower and upper carriage return to their maximum gap positions
- Belt gap setting – automatic setup from the product list [in conjunction with BELLEX]
- Contact pressure of the belts – automatic setup from the product list [in conjunction with BELLEX]
- Pneumatic belt pressure – automatic setup from the product list [in conjunction with BELLEX]



## Technical details:

<b>Drive power, servo motor</b>	2 x 1 kW
<b>Belt width</b>	40 / 80 mm
<b>Belt gap</b>	0 – 50 mm
<b>Maximum takeoff speed</b>	50 – 300 m/min

## EVERYTHING FROM A SINGLE SOURCE

Our integration into **PÜTZ GROUP** and the resulting **synergies** have enabled us to offer the matching inspection technology for inspecting surfaces and dimensional stability in addition to the machines and systems for plastic processing.

**WORLD  
MARKET  
LEADER**

**BELLAFORM offers everything from one single source ...**

... irrespective of whether it is about the upgrading of your systems, spare part supply or the construction of a new production line.

**We look forward to receiving your request!**

**Bellaform GmbH**  
 Marie-Curie-Straße 14  
 55435 Gau-Algesheim  
 GERMANY

Phone: +49 6725 91925-0  
 Fax: +49 6725 91925-200  
 info@bellaform.com  
 www.bellaform.com